

Fig. 1a

Jøtul F 162 / Jøtul F 163 / Jøtul F 162 C / Jøtul F 163 C

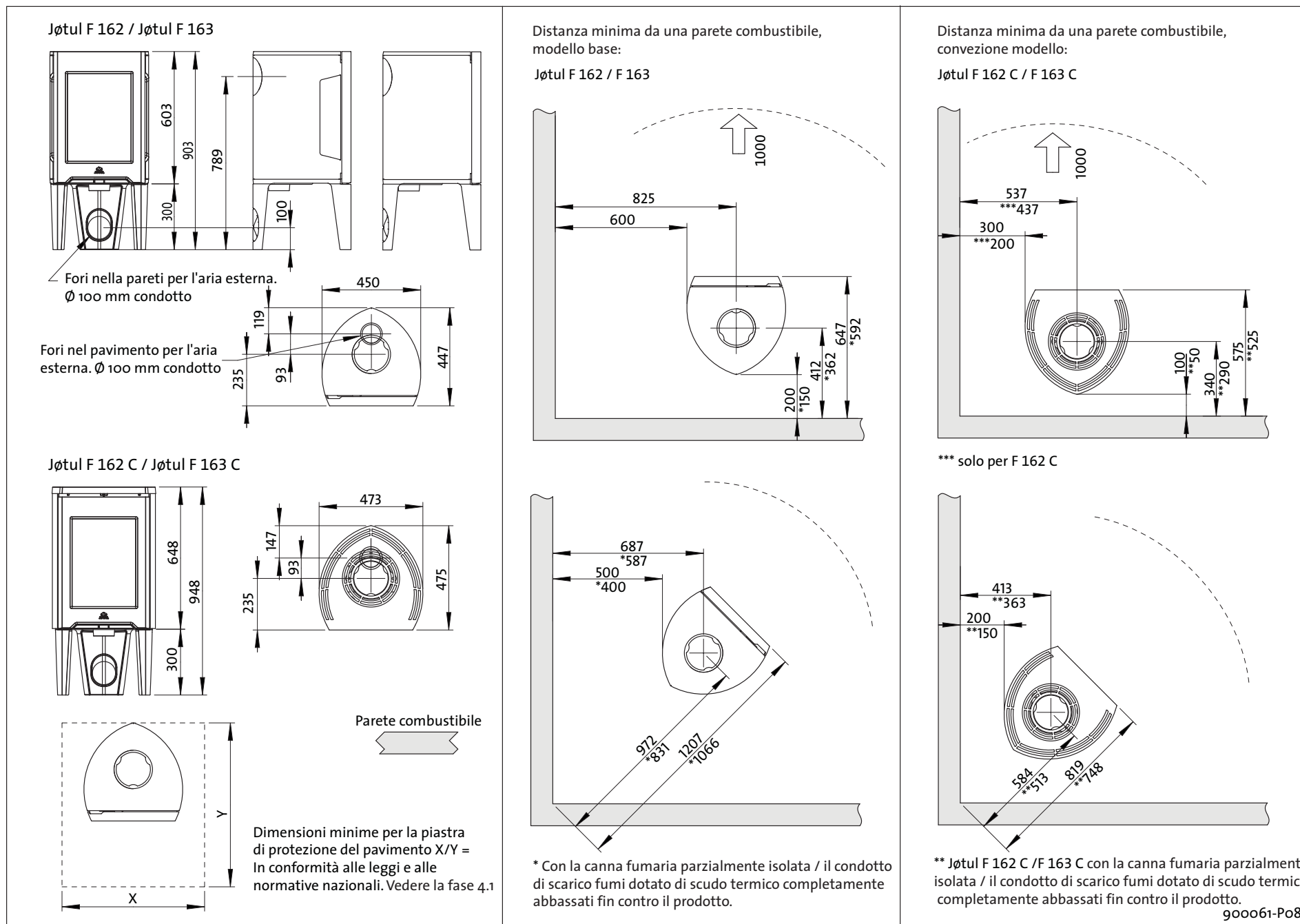



Fig. 1b

Jøtul F 162 / Jøtul F 163

Distanza minima dalla parete combustibile protetta da un muro tagliafuoco

 Parete combustibile
 Muro tagliafuoco

Externa

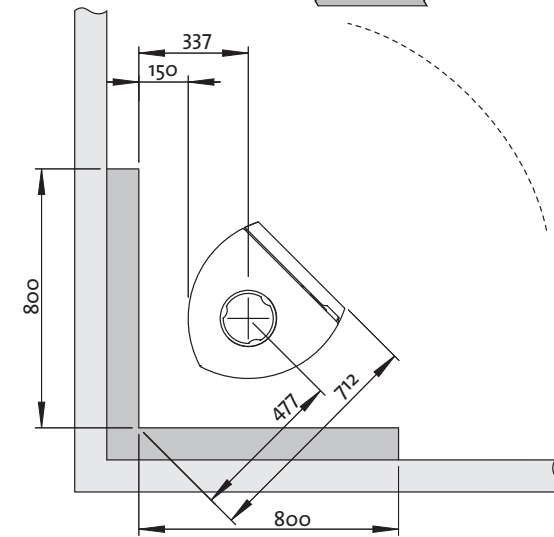
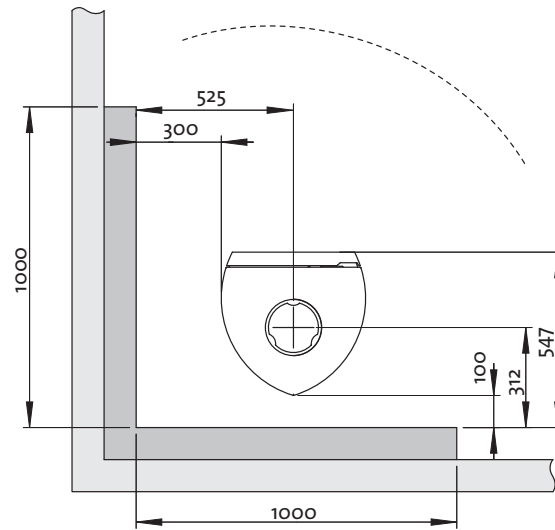
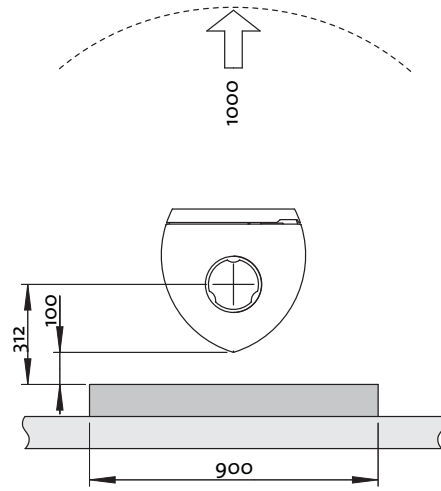

Integrata

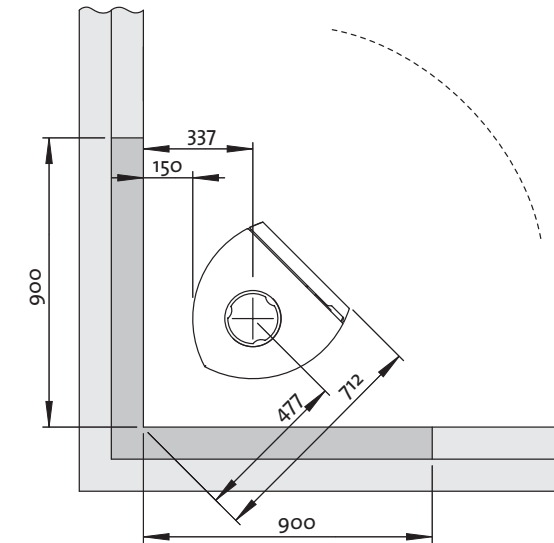
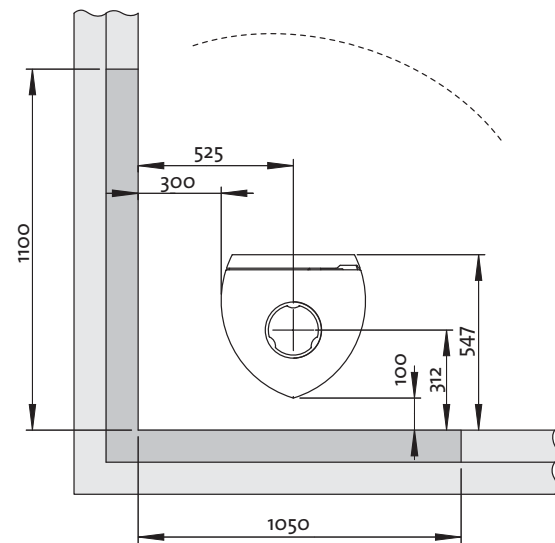
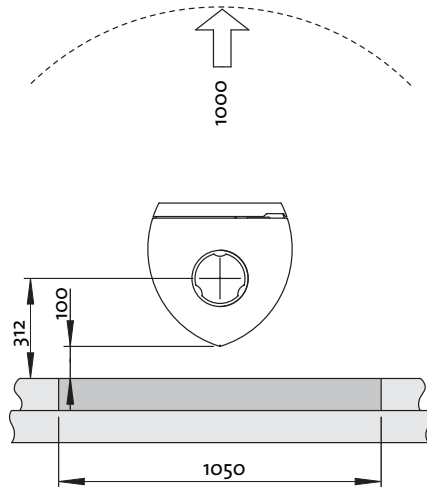

900061-Po8

Fig. 1c

Jøtul F 162 C / Jøtul F 163 C

Distanza minima dalla parete combustibile protetta da un muro tagliafuoco

Parete combustibile
Muro tagliafuoco

Externa

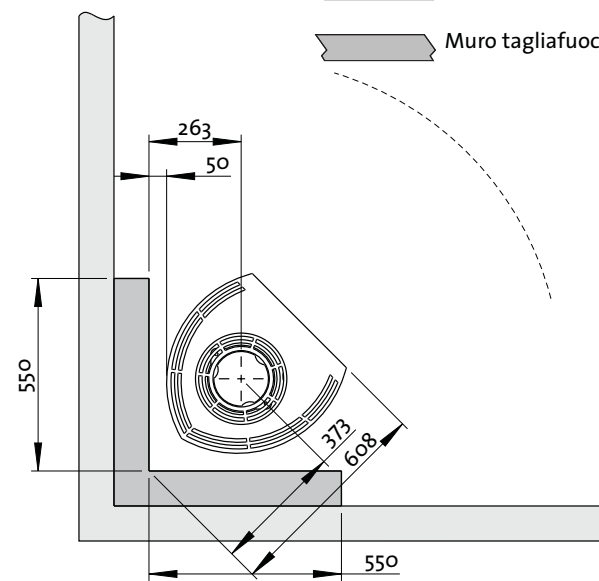
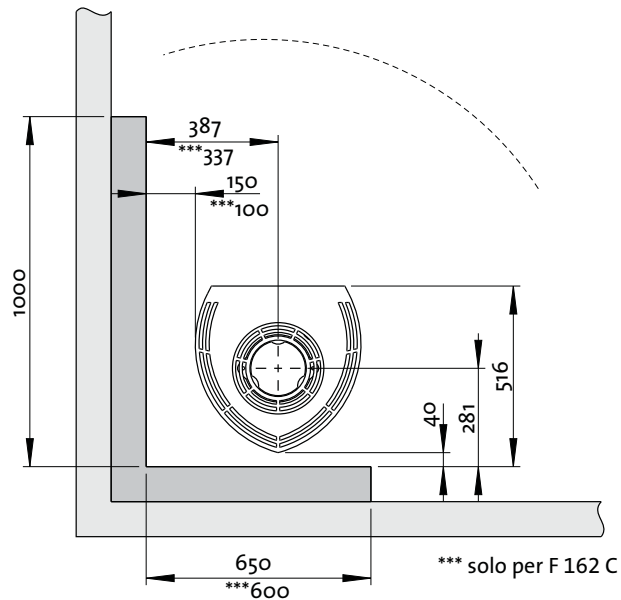
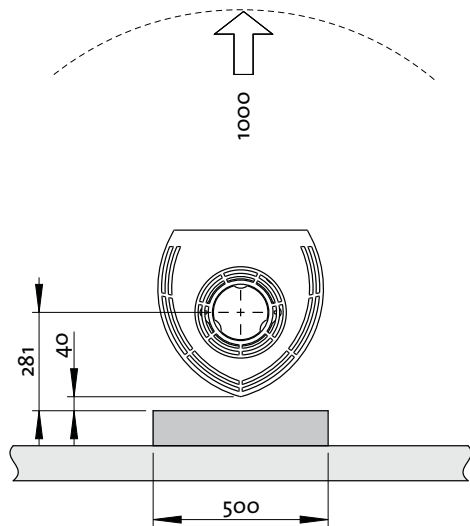

Integrata

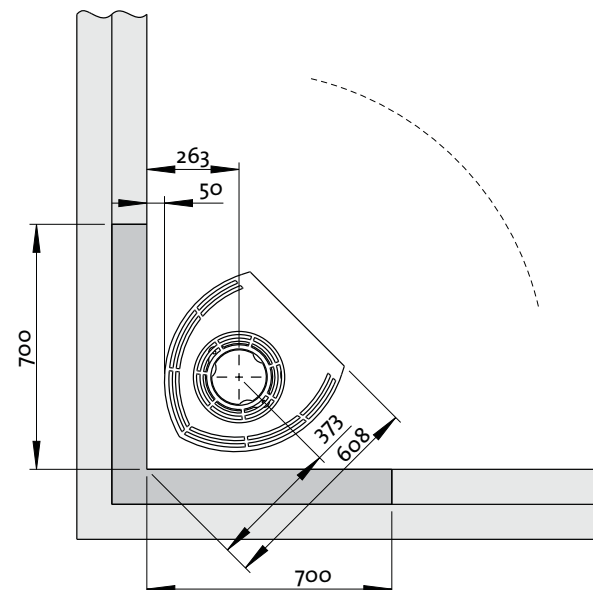
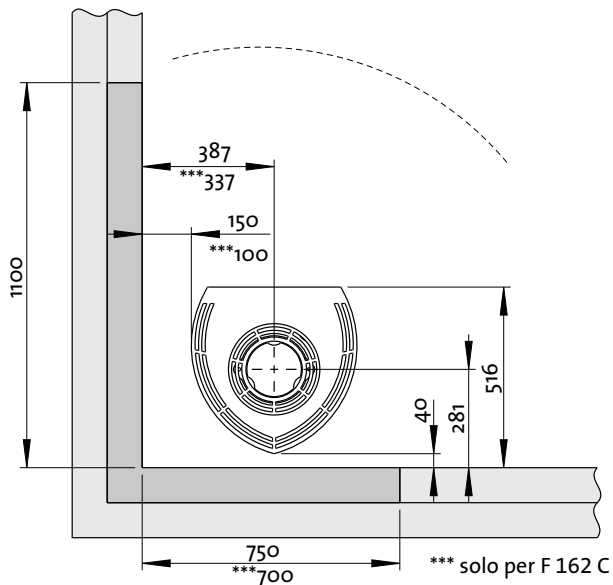
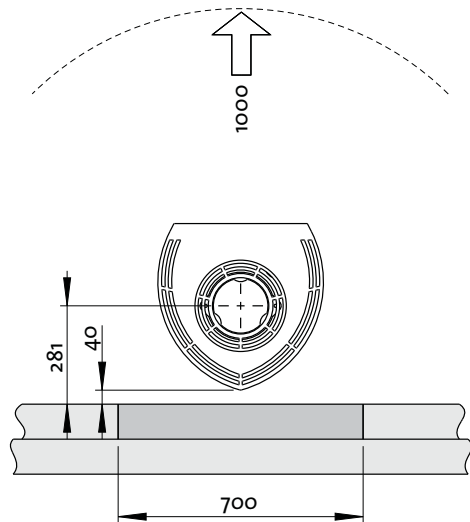

900061-Po8